

Nos. 711 & 911 Self-Opening Die Heads

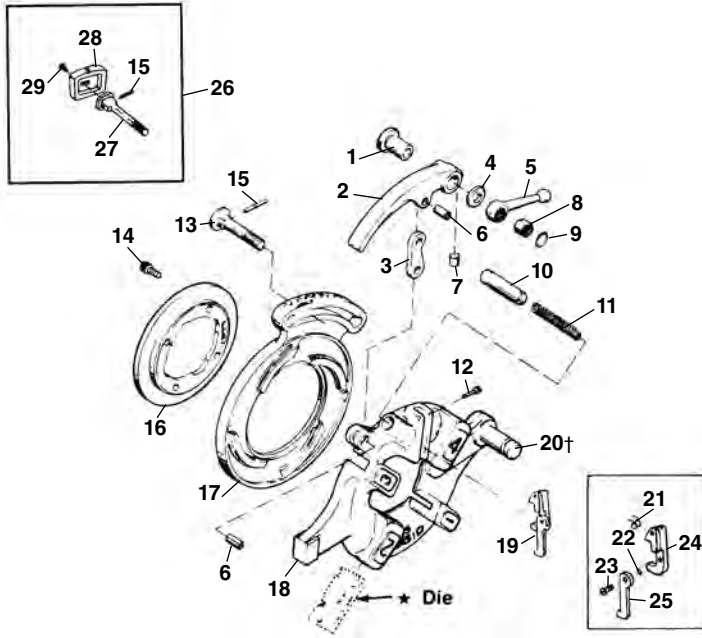

NOTE: Order parts by Catalog Number only. DO NOT order by Reference Number.

Ref. No.	Catalog No.	Description
—	26132	711 Self-Opening Die Head (NPT)
—	26137	911 Self-Opening Die Head (BSPT)
—	41382	911 Self-Opening Die Head f/Japan (BSPT)
—	46862	911 Self-Opening Die Head f/Europe
1	44240	Bushing
2	43830	Throw-out Lever
3	44265	Throw-out Link
4	44245	Thrust Washer
5	44260	Clamp Lever
6	44270	Spiral Pin
7	45055	Insert
8	44250	Nut
9	44255	Retaining Ring
10	44275	Throw-out Plunger
11	11565	Spring
12	44290	Trigger Screw
13	44235	Lock Screw
14	32205	Screw 1/4" - 20 x 5/8"
15	45050	Pin
16	97020	Retaining Ring
17	40942	Cam Plate (NPT)
17	97040	Cam Plate (BSPT)
18	26717	Head w/Post
19	44285	Trigger Assy.
19	32982	Adjustable Trigger Assy. (Europe)
19	44687	Stepped Trigger Assy. (Japan)
†20	59827	Post
21	39982	Spring
22	44460	O-Ring
23	39967	Screw (Left Hand)
24	39977	Trigger Pivot
25	39972	Adjustable Trigger (Europe)
	44672	Stepped Trigger (Japan)
	45327	Stepped Trigger (Europe)
26	45332	Adj. Gage Plate Assy.
27	46722	Adj. Lock Screw
28	46717	Adj. Gage Plate
29	47147	Button Head Screw

† - See Service Notes

Nos. 541, 542, 713 & 913 Quick-Opening Die Heads

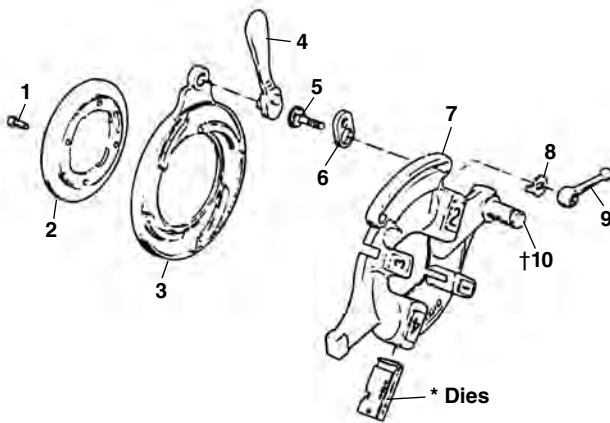

Ref. No.	Catalog No.	Description
—	26162	541 Quick-Opening Bolt Die Head 1/4" - 1"
—	26167	542 Quick-Opening Bolt Die Head 1 1/8" - 2"
—	26142	713 Quick-Opening Die Head (NPT) 1/4" - 2"
—	26147	913 Quick-Opening Die Head (BSPT) 1/4" - 2"
1	32205	Screw 1/4" - 20 x 5/8" (4)
2	23292	Retaining Ring L.H. (713, 913)
	46620	Retaining Ring (541)
	46625	Retaining Ring (542)
3	43360	Cam Plate L.H. (713, 913)
	43405	Cam Plate (541)
	43410	Cam Plate (542)
4	46520	Throw-out Lever (713, 913)
	46555	Throw-out Lever (541, 542)
5	39860	Lock Screw (713, 913)
	39955	Lock Screw (541, 542)
6	39950	Link
7	26897	Head w/Post & Latch Assembly (913)
	26982	Head w/Post (541)
	26987	Head w/Post (542)
	27267	Head w/Post & Latch Assembly (713)
8	39460	Lever Washer
9	39970	Clamp Lever
†10	59827	Post

† - See Service Notes

**811A
842
555
531B
532B
500A MONO**

Service Note

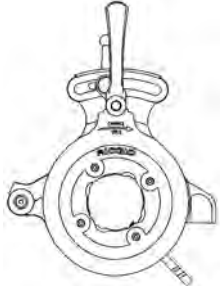

†2 Retaining Ring must be oriented as shown for proper oil flow.

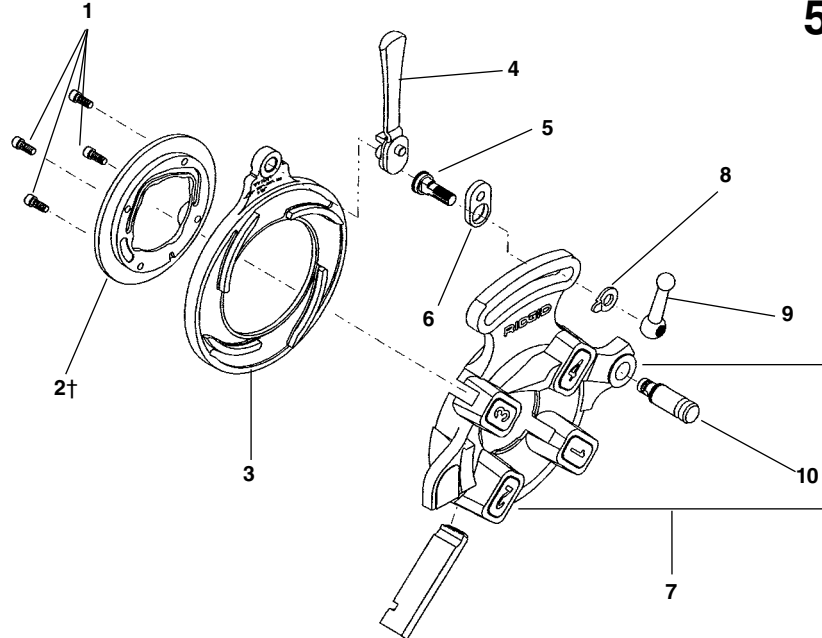

QUICK OPENING DIE HEADS

**NOTE: Order parts by Catalog Number only.
DO NOT order by Reference Number.**

Ref. No.	1	2†	3	4	5	6	7	8	9	10
Die Head & Catalog No.	Screw	Retaining Ring	Cam Plate	Throw-Out Lever	Lock Screw	Link	Head/w Post	Lever Washer	Clamp Lever	Post
811A (97065) 1/8"-2" RH NPT	32205	97020	43360	46520	39860	39950	40922	26957	39970	59832
842 (23282) 1/8"-2" LH NPT	32205	23292	43360	46520	39860	39950	23287	26957	39970	59832
555 (10491) 1/8"-3/4"	32205	24256	43365	46555	39860	39950	24006	26957	39970	59832
531B (97045) 1/4"-1" RH/LH	32205	46620	43405	46555	39955	39950	97055	26957	39970	59832
532B (97050) 1 1/8"-2" RH/LH	32205	46625	43410	46555	39955	39950	97060	26957	39970	59832
811A (97070) 1/8"-2" BSPT	32205	97020	43360	46520	39860	39950	40957	26957	39970	59832
842 (23297) 1/8"-2" LH (BSPT)	32205	23292	43360	46520	39860	39950	23202	26957	39970	59832
500A Mono (1/8"-3/8") RH 1/8" (41032) 1/4" (41037) 3/8" (41042)	32205	1/8"-41862 1/4"-41867 3/8"-41872	43305	46555	47140	39950	41907	26957	46820*	59832
500A Mono (1/2"-3/4") RH 1/2" (41047) 3/4" (41062)	32205	1/2"-41877 3/4"-41882	43300	46555	47140	39950	41912	26957	46820*	59832
500A Mono (1"-1 1/4") RH 1" (41057) 1 1/4" (41062)	32205	1"-41887 1 1/4"-41892	43295	46555	47140	39950	41917	26957	46820*	59832
500A Mono (1 1/2"-2") RH 1 1/2" (41067) 2" (41072)	32205	1 1/2"-41897 2"-41902	43290	46555	47140	39950	41922	26957	46820*	59832

*Hex Nut For Mono Die Heads

610 Die Head – Type 2

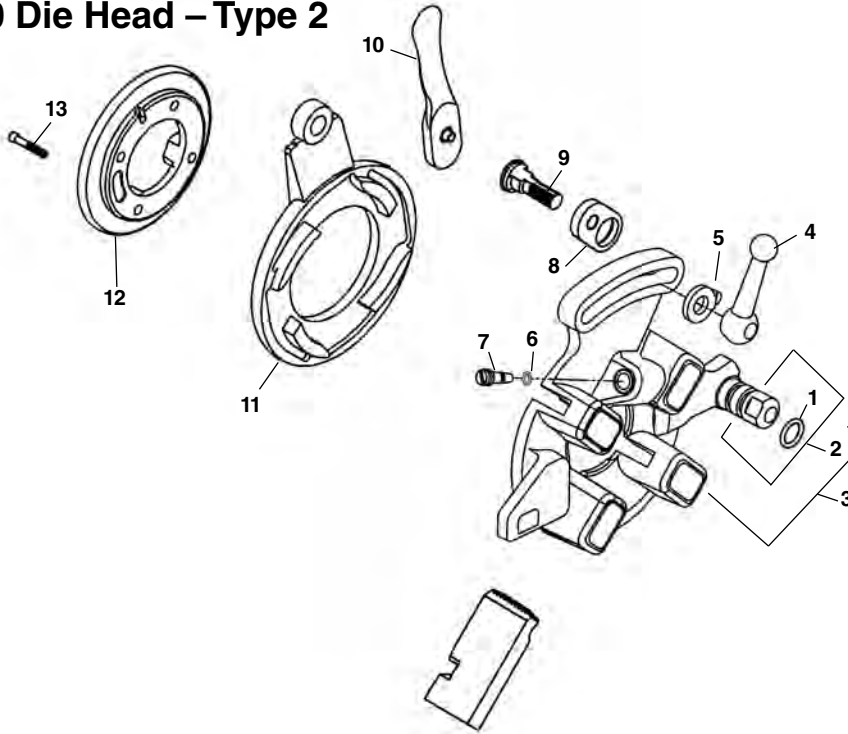

NOTE: Order parts by Catalog Number only.
DO NOT order by Reference Number.

Ref. No.	Catalog No.	Description
—	67817	610 Die Head
1	69392	O-Ring
2	69292	Post
3	69302	Die Head Body w/Post & O-Ring
4	39970	Clamp Lever
5	26957	Washer
6	69182	O-Ring
7	69177	Needle Pin
8	39950	Throwout Link
9	39860	Lock Screw
10	46555	Throwout Lever
11	69442	Cam Plate
12	69352	Retaining Ring
13	32205	Screw 1/4" - 20 x 5/8" Socket Head (4)

354 Cutter

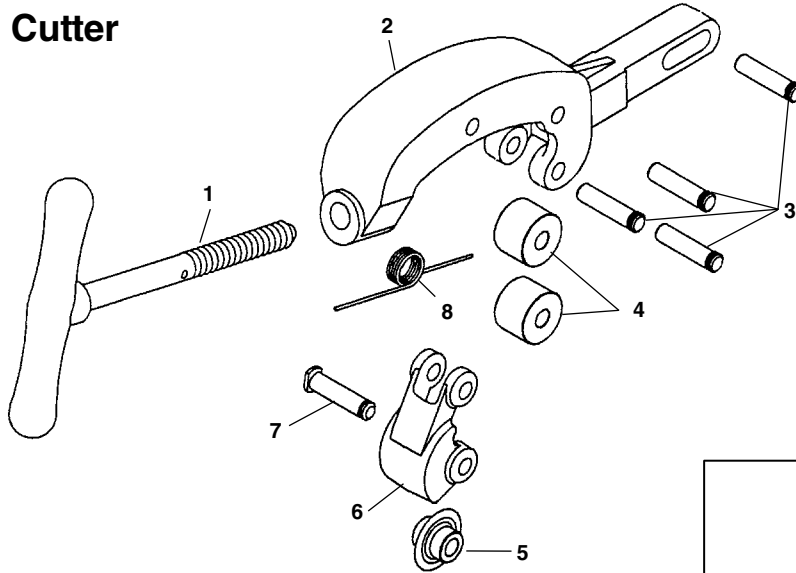

Ref. No.	Catalog No.	Description
—	68877	354 Cutter Assembly
1	69007	Feedscrew & Handle
2	69017	Cutter Frame
3	46662	Roller Pin (4)
4	34775	Roll (2)
5	33105	F3 Cutter Wheel
6	69012	Wheel Housing
7	34780	Pin & Clip
8	58617	Torsion Spring

334 Reamer

Ref. No.	Catalog No.	Description
—	68872	334 Reamer Assembly
1	68997	Screw #8-32 x 7/16" Flat Head
2	68977	Reamer Blade
3	68992	Reamer Arm w/Cone
4	39885	Wave Washer
5	68987	Clevis Pin
6	69002	3/32" x 3/4" Roll Pin

